

Features

- Methanol safe 250psi Pump
- Includes VC-100 Injection Controller
- FCS-10 Fluid Control Solenoid
- 3qt Fluid Tank
- High Atomization Injection Nozzles
- 15 Feet high pressure hose
- Complete Install Instructions
- Easy Installation and Setup
- 1 Year Warranty

Description:

Since 2003, the Labonte MotorSports VC-100 has been delivering reliable water-methanol injection control for diesel enthusiasts. Now the original manufacture has designed a complete system for diesels that is a step above other injection systems for a reasonable price.

The DIS-100 from Labonte MotorSports provides a cost effective way to lower EGTs up to 250F and add up to 70hp to your diesel engine. This universal system is easy to install in your Ford, GM, or Dodge truck. Designed for turbo diesel engines running over 20psi of boost.



OPERATING CHARACTERISTICS

| Characteristic | Min | Typ. | Max | Units |
|-----------------------|------|------|-----|-------|
| Operating Temperature | 0 | ---- | 105 | deg C |
| Supply Voltage | 9 | 13.8 | 16 | Vdc |
| Drive Current | ---- | 4 | 8 | Amps |
| Pump Pressure | 60 | ---- | 250 | psi |

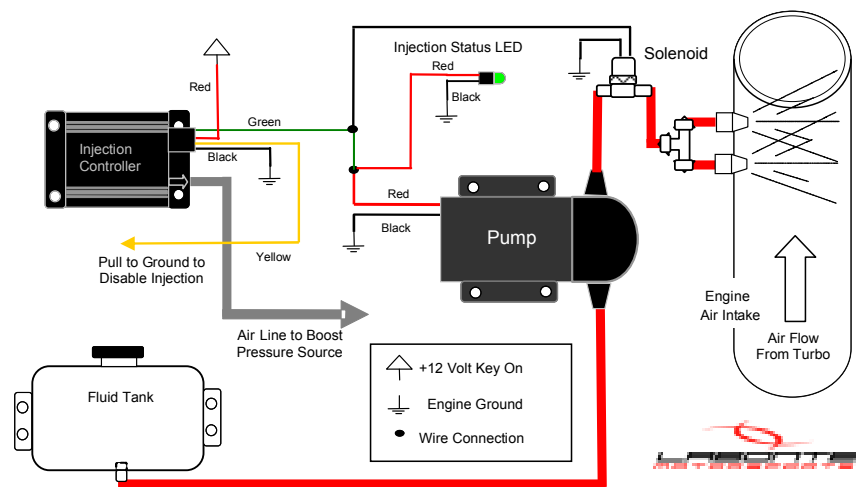

Typical System Install

Nozzle size based on RWHP

| | 175 - 250 | 250 - 300 | 325 - 400 | 450 - 600 |
|---------|-----------|-----------|-----------|-----------|
| Install | M7 | M10 | M7 & M10 | M10 & M14 |