

Features

- Methanol safe 250psi Pump
- Includes VC-25 Injection Controller
- FCS-10 Fluid Control Solenoid
- 3qt Fluid Tank
- High Atomization Injection Nozzles
- 15 Feet high pressure hose
- Complete Install Instructions
- Easy Installation and Setup
- 1 Year Warranty



Description:

Since 2003, the Labonte MotorSports VC-25 has been delivering reliable water-methanol injection control for diesel enthusiasts. Now the original manufacture has designed a complete system for diesels that is a step above other injection systems for a reasonable price.

The DIS-25 from Labonte MotorSports provides a cost effective way to lower EGTs up to 250F and add 70hp to your diesel engine. This universal system is easy to install in your Ford, GM, or Dodge truck. Designed for turbo diesel engines running up to 20psi of boost.

OPERATING CHARACTERISTICS

Characteristic	Min	Typ.	Max	Units
Operating Temperature	0	----	105	deg C
Supply Voltage	9	13.8	16	Vdc
Drive Current	----	4	8	Amps
Pump Pressure	60	----	150	psi

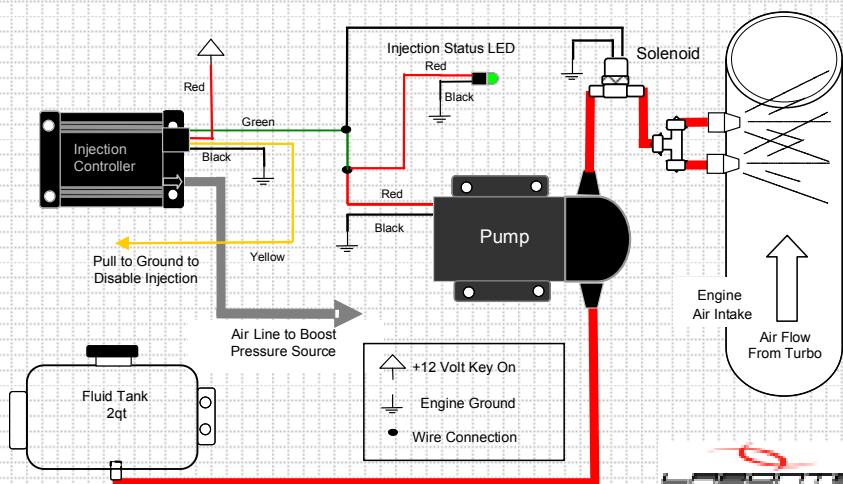

Typical System Install

Install	Nozzle size based on RWHP			
	175 - 250	250 - 300	325 - 400	450 - 600
	M7	M10	M7 & M10	M10 & M14